



**STACK  
STACK  
STACK**

---

## Street Dash

## Users Guide



- Labels on wiring, 6
- Lamps. *See* Warning lights
- Lap number
  - display, 10
- Lap time, 15
  - display, 10
  - recording manually, 10, 15
  - resetting, 15, 27
- Lap timing sensor
  - installation, 36
  - wiring label, 6
- Lights. *See* Warning lights
- MSS connector, 34
- Odometer
  - display, 9
- Oil pressure
  - alarm, 14, 18
  - display, 9, 10
- Oil pressure sensor
  - wiring label, 6
- Oil temperature
  - alarm, 14, 18
- Oil temperature sensor
  - installation, 31
  - wiring label, 6
- Operating the system, 8
- Optional components, 4
- Peak values, 11
  - displaying, 12, 27
  - memory, 13
  - resetting, 12, 27
- Performance parameters, 1
- Power supply, 6, 7
- Pressure sensors, 31
- Redisplaying last alarm, 15
- Resetting peak values, 12
- Resistor connection to coil, 30
- RPM Gate Value. *See* Gate Value
- Shift light. *See* Gear shift warning light
- Shift RPM. *See* Gear shift RPM
- Showing the last alarm, 15
- Speedometer, 7
- Switches
  - functions - normal operation, 27
  - installation, 27
  - operation - configuration, 17
  - summary of functions, 52
  - wiring labels, 6
- Switching the system on, 8
- Tachometer, 5
- Tell-tales. *See* Peak values
- Temperature sensors
  - installation, 31
- Temperatures
  - minimum displayable, 9
  - water. *See* Water temperature, *See* Water temperature
- Template for the Display Module, 49
- Tools needed, 26
- Trackside infra-red beacon. *See* Beacon
- Trip meter
  - resetting, 27
- Troubleshooting, 40
- Unpacking, 4
- Velcro. *See* Dual-Lock
- VSS Pulse amplifier
  - adjustment, 34
  - connection, 34
  - installation, 32
  - specifications, 35
- Warning lights
  - additional, 28
  - alarms. *See* Alarm warning light
  - gear shift. *See* Gear shift warning light
  - installation, 28
  - maximum power, 28
- Water temperature
  - alarm, 14, 18
  - display, 9, 10
- Water temperature sensor
  - installation, 31
  - wiring label, 6
- Wheel
  - circumference, 18, 21
  - pulses per revolution, 18, 21
- Wheel speed sensor
  - wiring label, 6
- Wiring harness, 6
  - extenders, 38
  - installation, 38
  - schematic diagram, 51
- Wiring labels, 6

## Preface

### Congratulations

Congratulations on your purchase of the Street Dash Display from Auto Meter.

This system will give you a wealth of information to enable you to obtain the maximum safe performance from your vehicle.

### Purpose of this manual

This manual will help you install and use your Auto Meter Street Dash Display. It explains how to set up and configure the system for your vehicle.

### Units of Measure

Units used in the various display parameters are shown in the following table.

Parameter Type	US Version
Speed	MPH
Distance	Miles
Temperature	°F
Wheel Circumference	Inches
Fuel level	Gallons (US)
Pressure	PSI

## Related Products From Auto Meter

If you need information about other Auto Meter products, these can be obtained from Auto Meter or from your local Auto Meter dealer. Products available from Auto Meter include:

- Tachometers
- Playback Tachometers
- Speedometers
- Boost Gauges
- Analog Sensors
- Digital Sensors
- Data Logging Systems
- Display and Logging Systems
- Display and Analysis Software

Please visit [www.autometer.com](http://www.autometer.com) for a complete listing.

## Who to Contact at Auto Meter in Case of Difficulty

Auto Meter and its approved distributors provide a comprehensive Technical Help service to assist with your inquiries. Contact Auto Meter toll free at 866-248-6357 for technical support or email us at [service@autometer.com](mailto:service@autometer.com).

You may also visit us on the web at [www.autometer.com](http://www.autometer.com) to view accessories, instructions, view FAQ's and for installation tech tips.

Auto Meter ® is a registered trademark of Auto Meter Products Inc.

Information in this publication is subject to change without notice and does not represent a commitment on the part of Auto Meter. No responsibility is accepted for error or omission. Copyright © 2009 Auto Meter Products Inc

## Index

- Alarm warning light
  - external, 28
  - wiring label, 6
- Alarms, 13
  - battery voltage, 14, 18
  - clearing, 8, 14, 27
  - fuel level, 14
  - fuel pressure, 14, 18
  - fuel warning, 18
  - oil pressure, 18
  - oil pressure, 14
  - oil temperature, 14
  - redisplaying, 15
  - showing last, 15
  - start-up, 7
  - switching on or off, 17
  - water temperature, 18
  - water temperature, 14
- Analog tachometer, 5
- Battery voltage
  - alarm, 14
  - display, 10
- Battery voltage alarm, 18
- Beacon, 37
  - battery condition lamp, 38
  - power supply, 38
- Calibration
  - fuel level, 22
  - wheel speed, 21
- Clearing an alarm, 14
- Components, 4
- Configurable parameters, 18
- Configuring the display system, 16
  - switches to enter configuration mode, 27
- Digital display panel, 5
- Dimensions, 26
- Display
  - backlighting, 8
- Display layers, 8
  - changing layer, 27
  - layer 1, 9
  - layer 2, 9
  - layer 3, 10
  - layer 4, 10
  - layer 5, 10
- Display module, 5
  - dimensions, 26
  - positioning, 27
  - template, 49
- Dual-Lock, 33
- Electronic ignition connection, 30
- Engine
  - cylinders, 18
  - ignition pickup, 29
- Engine speed (RPM), 28
- Engine speed (RPM), wiring label, 6
- External warning lights. *See* Warning lights
- Fitting the display module, 26
- Fuel level
  - alarm, 14
  - calibration, 22
  - display, 9
- Fuel Level
  - calibration Table, 25
- Fuel level sensor
  - wiring label, 6
- Fuel pressure
  - alarm, 14, 18
  - display, 10
  - wiring label, 6
- Fuel pressure sensor
  - configuration, 21
- Fuel tank sender
  - calibration, 18
  - Installation, 35
- Fuel warning light, 18
- Gate RPM, 18
- Gate value, 11, 12, 13
  - delay, 11
- Gear shift RPM, 18
- Gear shift warning light, 15
  - wiring label, 6
- High oil temperature alarm, 18
- High water temperature alarm, 18
- Ignition connection, 29
- Infra-red beacon. *See* Beacon
- Installing the Street Dash, 26
- Internal Battery Low message, 13

## 12 Month Limited Warranty

Auto Meter Products, Inc. warrants to the consumer that all Auto Meter High Performance products will be free from defects in material and workmanship for a period of twelve (12) months from date of the original purchase. Products that fail within this 12 month warranty period will be repaired or replaced at Auto Meter's option to the consumer, when it is determined by Auto Meter Products, Inc. that the product failed due to defects in material or workmanship. This warranty is limited to repair or replacement of parts in the Auto Meter instruments. In no event shall this warranty exceed the original purchase price of the Auto Meter instruments nor shall Auto Meter Products, Inc. be responsible for special, incidental or consequential damages or costs incurred due to the failure of this product. Warranty claims to Auto Meter must be transportation prepaid and accompanied with dated proof of purchase. This warranty applies only to the original purchaser of product and is non-transferable. All implied warranties shall be limited in duration to the said 12 month warranty period. Breaking the instrument seal, improper use or installation, accident, water damage, abuse, unauthorized repairs or alterations voids this warranty. Auto Meter Products, Inc. disclaims any liability for consequential damages due to breach of any written or implied warranty on all products manufactured by Auto Meter.

For Service Send To: AUTO METER PRODUCTS , INC.  
413 W. Elm St., Sycamore, IL 60178 USA (866) 248-6357

Email us at [service@autometer.com](mailto:service@autometer.com)  
<http://www.autometer.com>

## Contents

<b>Preface</b>	<b>i</b>
Related Products From Auto Meter	ii
Who to Contact at Auto Meter in Case of Difficulty	ii
<b>Contents</b>	<b>iii</b>
<b>Chapter 1. Introducing the Display System</b>	<b>1</b>
Speed Sensor	2
How to Use this Manual	3
<b>Chapter 2. Getting Started</b>	<b>4</b>
The Display Module	5
Wiring Harness	6
Connecting the Components	7
<b>Chapter 3. Operating the Display System</b>	<b>8</b>
Switching the Display System On	8
Changing the Display Layers	8
Peak Values (Tell Tales)	11
Alarms	13
Lap Times	15
Gear Shift Light	15
<b>Chapter 4. Configuring the Display System</b>	<b>16</b>
Configuration Mode	16
Wheel Pulses and Circumferences	21
Configuring the Fuel Pressure Sensor (optional)	21
Calibrating the Fuel Level	22
<b>Chapter 5. Installing the Display System</b>	<b>26</b>
Who can install the Display System?	26
Tools Needed to Install the Display System	26
Preconfigured Display Systems	26
Fitting the Display Module	26
Switches	27
Warning Lights	28
Shift Light	28
Engine Speed (RPM) Measurement	28
Connecting the Display System to the Ignition System	29
Pressure Sensors	31
Temperature Sensors	31
VSS Pulse Amplifier Interface	32
Fuel Tank Sender	35
Lap Timing Sensor (Optional)	36

---

Trackside Infra-Red Lap Beacon (Optional)	37
Wiring harness	38
Checks and Alarms	39
<b>Chapter 6. Troubleshooting</b>	<b>40</b>
<b>Appendix A. Template for the Display Module</b>	<b>49</b>
<b>Appendix B. Wiring Harness Diagram</b>	<b>51</b>
<b>Appendix C. Summary of Switch Functions</b>	<b>52</b>
<b>Appendix D. Service and Support</b>	<b>53</b>
Service	53
12 Month Limited Warranty	54
<b>Index</b>	<b>55</b>

---

## **Appendix D. Service and Support**

### **Service**

For service send your product to Auto Meter in a well packed shipping carton. Please include a note explaining what the problem is along with your phone number. Please specify when you need the product back. If you are sending product back for Warranty adjustment, you must include a copy (or original) of your sales receipt from the place of purchase.

## Appendix C. Summary of Switch Functions

### Normal Operation

Switch or Switches	Functions
Switch 1	Show the peak values
Switch 2	Clear Alarm or Show Last Alarm
Switch 3	Clear Alarm or Change Display Layer
Switch 4	Reset the trip distance to zero and start the lap timer. The trip distance is reset after each lap.
Switches 1 & 2 together	Put system into configuration mode.
Switches 1 & 4 together	Reset the peak values and lap times.

### System Configuration Mode

Switch or Switches	Functions
Switch 1	Decrease the alarm value of the parameter being displayed
Switch 2	Increase the alarm value of the parameter being displayed
Switches 1 & 2 together	Enable or disable an alarm for the parameter being displayed
Switch 3	Display the next configurable parameter
Switches 1 & 2 together	Enter Fuel Calibration mode (when applicable)
Switch 4	Exit configuration mode and return to normal operation mode

### Fuel Calibration Mode

Switch or Switches	Functions
Switches 1 & 2 together	Enter Fuel Calibration mode
Switch 1	Decrease tank quantity value
Switch 2	Increase tank quantity value
Switch 3	Confirm value
Switch 4	Cancel and leave original calibration set

## Chapter 1. Introducing the Display System

The Auto Meter Street Dash Display System monitors and displays a range of values, known as performance parameters, needed for effective car and driver management in most driving situations.

The display combines an analog tachometer with a digital display for the following performance parameters:

1. Vehicle speed (MPH)
2. Engine speed (RPM)
3. Oil pressure
4. Oil temperature
5. Water temperature
6. Fuel Pressure (optional)
7. Fuel level (0-1.3K Ohms)
8. Battery Voltage
9. Lap times (last completed and best)

You can view the peak values (tell-tales) for all the parameters.

This system provides a red alarm light to alert the driver that a warning condition has been detected. The warning conditions are based on preset alarm values for the following performance parameters:

1. Low oil pressure
2. High oil temperature
3. High water temperature
4. Low fuel pressure
5. Fuel level.  
The fuel level alarm is indicated by the amber warning light; the unit does not display any message for the fuel level alarm.
6. Low Battery voltage

When the warning condition alarm light is switched on, a warning message is shown on the digital display to identify the condition. You can enable or disable the warning system for each parameter individually.

You can cancel the warning message by pressing Switch 2 or 3. Doing this does not turn off the warning condition alarm light, which stays on until the condition no longer applies.

You can redefine the preset alarm values for each parameter to those which are more suitable for your vehicle.

The system provides outputs for two external warning lights:

- a gear shift warning light that is based on an RPM value that you define for your vehicle
- an additional alarm warning light for the alarms described on previous page

The Street Dash Display can also be fitted with an optional lap timing sensor and fuel pressure sensor.

### Speed Sensor

This system obtains the vehicle's speed from pulses generated by the VSS (vehicle speed sensor) located in the transmission, on the driveshaft, or from a wheel speed sensor.

## Appendix B. Wiring Harness Diagram

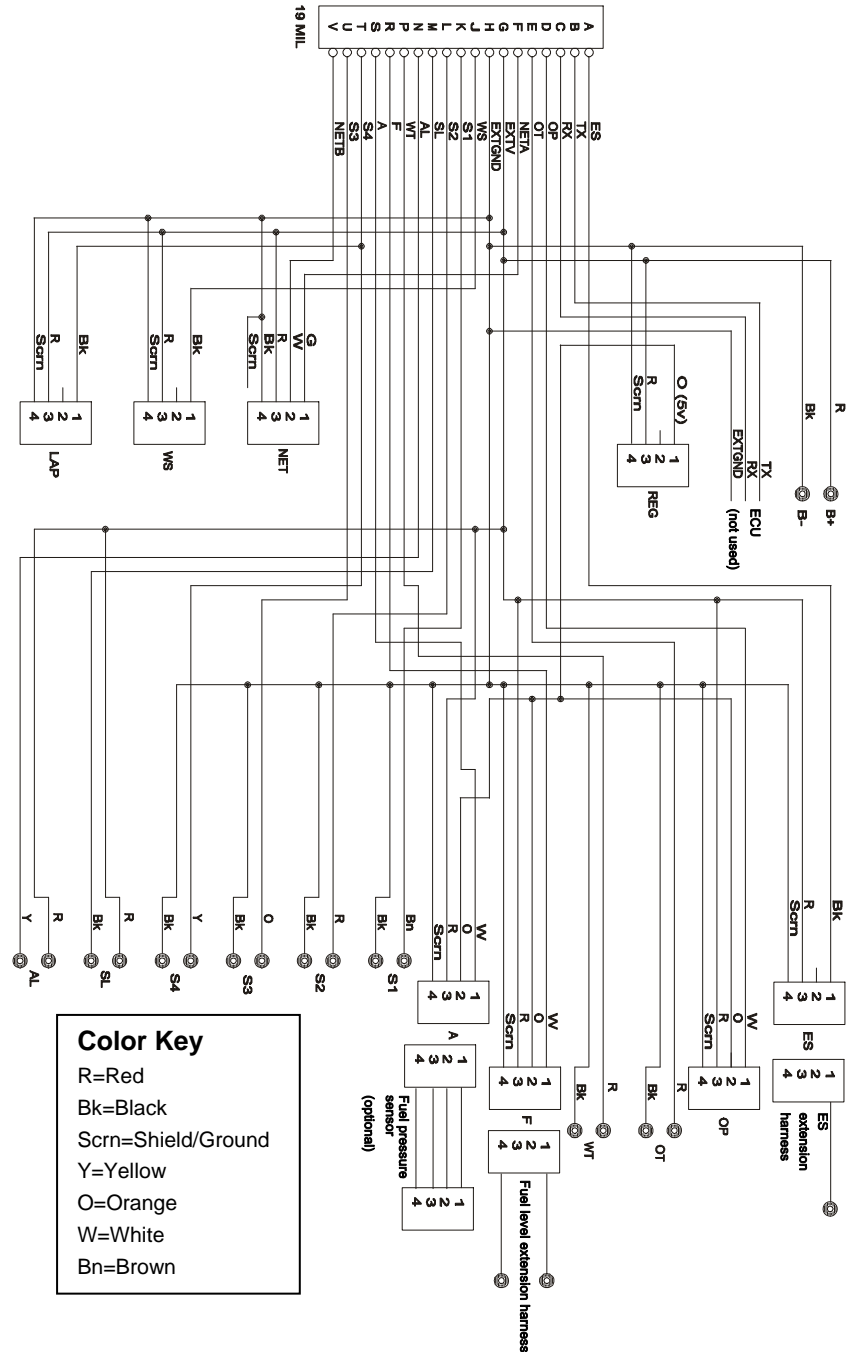



## How to Use this Manual

Auto Meter recommends that you unpack and connect the components in the system **before** you install it in your vehicle. This will enable you to familiarize yourself with operating the display and configuring it for the vehicle in which you intend to install it.

This manual starts by taking you through the process of setting up the system before installation, operating the digital display, configuring the system, setting the alarm values and installing it in the vehicle. By the end of Chapter 2, you will have set up the system so that you will be assured that it is functioning normally. You can then read Chapter 3 and practice using its functions. Chapter 4 takes you through configuring it for your vehicle. Chapter 5 explains how to install it in the vehicle. Chapter 6 provides a set of trouble-shooting guidelines.

A full size template for the dashboard cut-out for the Street Dash Display is provided in Appendix A along with a dimensional drawing on page 26. There is a schematic diagram of the wiring harness in Appendix B.

## System Overview

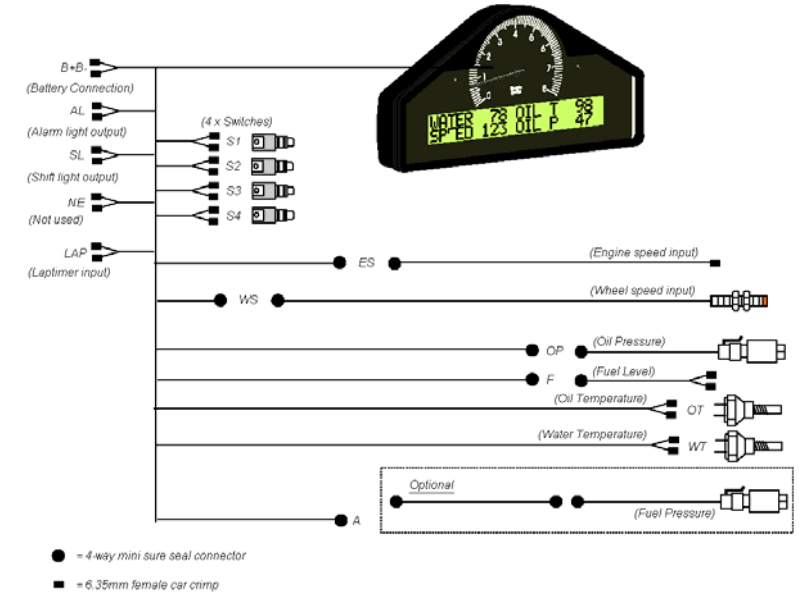

## Chapter 2. Getting Started

This chapter guides you through the initial unpacking and setting up of the equipment for pre-installation checks and familiarization with its operation.

### Standard Street Dash Display System Items

The Street Dash Display System is supplied with the following standard components:

Quantity	Description
1	Display Module with 2 mounting brackets
1	Wiring Harness
1	Fuel Level Extension Harness
1	Oil Pressure Sensor
2	Oil & Water Temperature Sensors
4	Switches (supplied with and to be connected to the wiring harness)
1	Pulse Amplifier for VSS speed input

### Optional Street Dash Display System Items

The optional fuel pressure sensor consists of the following component:

Quantity	Description
1	Fuel Pressure Sensor (Model # 2210)

The optional lap timing system consists of the following components:

Quantity	Description
1	Infra-red Lap Beacon (Model # 5266)
1	Lap Timing Receiver (Model # 5267)

## Appendix A. Template for the Display Module

Use the template on the following page for cutting out an aperture for the Display System.

No.	Symptom	Possible Cause	Remedy	Notes
28	Lap time is not displayed automatically (Automatic receiver is fitted)	Lap marker receiver lead faulty	Check lap marker wiring	Press lap switch 4.
		Lap marker receiver faulty	Replace lap marker receiver	If display changes, replace receiver after checking its wiring.
29	The display unit functions correctly until the engine is started whereupon the digital display either freezes or flashes. The display functions correctly as soon as the engine is stopped.	High levels of electrical interference	Fit suppression type spark plug wires	

## The Display Module

The Display Module consists of an analog tachometer, two indicator lights and a digital display panel.

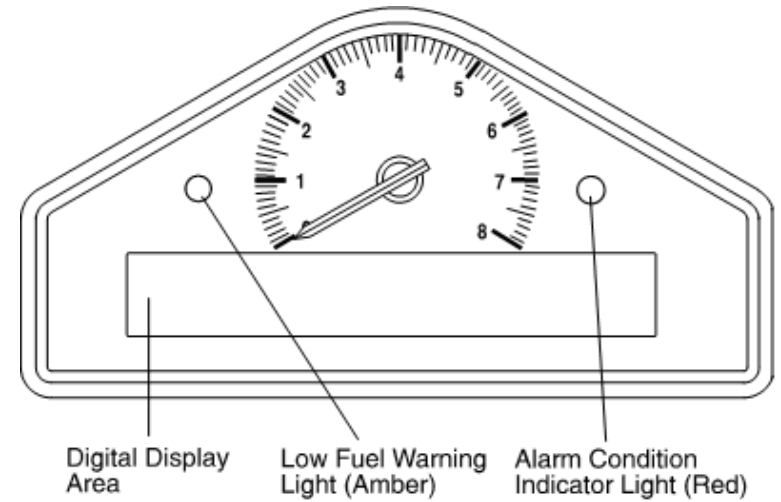

The Display Module is connected to a variety of sensors by a wiring harness. The wiring harness has a 19-way military connector for connection to the Display Module.

## Wiring Harness

Each of the wires in the harness is labeled.

Labels on Short Cables	Connection To
S1 to S4	Switches 1 to 4
WS	V.S.S. speed input (MPH)
SL	Gear shift warning light
AL	Alarm warning light
NET	Not used
LAP	Optional in-car lap timing sensor

Labels on Long Cables	Connection To
A	Fuel pressure sensor (optional)
ES	Engine speed (RPM)
OT	Oil temperature sensor
WT	Water temperature sensor
OP	Oil pressure sensor
F	Fuel level sensor
B +	Switched 12V Power
B -	Battery negative (Chassis) ground

No.	Symptom	Possible Cause	Remedy	Notes
25	No alarms for water, oil or fuel (temperatures and pressures) being displayed	All the alarms have been switched off	Switch on the required alarms	Alarms only operate when the engine is running above the RPM gate value.
		The engine RPM gate value is set too high	Reset the RPM gate to a lower value.	
26	Display and alarm light flash when the engine is running	Intermittent alarm caused by a parameter with its alarm level set too close to the normal operating value	Either change the value for the alarm or turn the alarm off	Press Switch 2 to see which sensor is causing the alarm
27	Fuel level reading does not change	<ol style="list-style-type: none"> <li>Fuel sender wiring not connected correctly</li> <li>Faulty fuel sender</li> <li>Fuel sender not suitable for use with Street Dash Display System</li> <li>Fuel sender not calibrated</li> </ol>	<ol style="list-style-type: none"> <li>Check wiring</li> <li>Check fuel sender</li> <li>Check with your Auto Meter dealer for suitable alternative</li> </ol> <p>See Chapter 4 for information on how to calibrate the fuel sender.</p>	If there is no reading from the fuel sender, remove the fuel sender unit from the tank, ground it to the vehicle with a clip lead and move it by hand to verify that the voltage reading on the red lead changes. The voltage on the red lead should range from 0V to 5V.

No.	Symptom	Possible Cause	Remedy	Notes
22	Tachometer reading erratic, pointer jumps high or low	Incorrect wiring	Reconnect the tachometer as specified in this manual	
		Signal from ignition system or coil is noisy	Condition the ES signal by placing a resistor in line with the ES wire	Resistor values: 10K ohms for dedicated tach output; 47K Ohms for coil connection (Non-CDI); 100K Ohms for coil connection (CDI). Resistors 1/2W 5% 350v
23	Displayed speed value too high or too low by a constant %-age amount.	System configured with wrong number of targets per wheel revolution	Reconfigure the system with correct values	
		System configured with wrong circumference.		
24	No speed reading Speed reading erratic, value jumps high or low	Faulty sensor and/or wiring	Check sensor indicator for correct operation	Rotate the wheel by hand and check that the sensor indicator lights up as each target passes the sensor
		1. Pulse amplifier not connected 2. Pulse amplifier out of adjustment	Rotate wheels and check the LED on the VSS Pulse Amplifier for pulse signals	

## Connecting the Components

1. Connect the wiring harness to the display module.
2. Connect the four switches to the cables labeled S1 to S4.
3. Connect each of the sensors that you have purchased to the appropriate wire in the wiring harness, as shown above.
4. Connect a 12v DC power supply or battery to the power input cable. **NEVER** use a battery charger to supply power to the display module.
5. Switch on the 12v DC power supply.

The Display Module should start up with an alarm signal indicating low oil pressure.

Note that whenever a warning message is shown on the top line of the digital display, the speed of the vehicle always continues to be shown in the center of the bottom line.

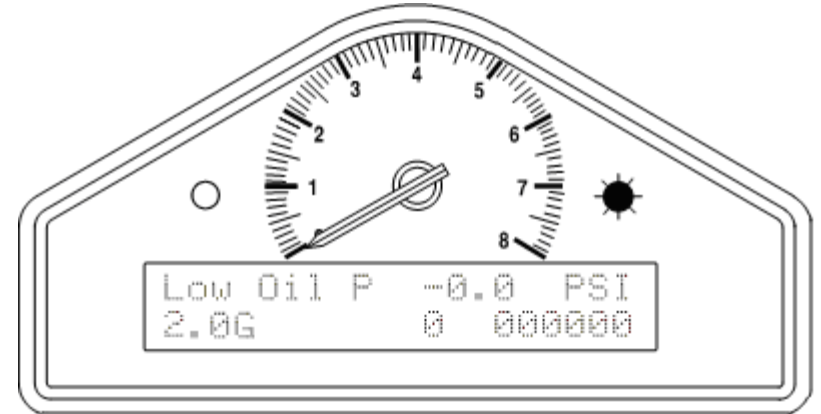

You can now proceed to familiarize yourself with operating the Display Module.

## Chapter 3. Operating the Display System

This chapter takes you through the operation of the system so that you can familiarize yourself with its use before you install it in the vehicle.

### Switching the Display System On

You will have switched the system on already if you have followed the instructions in the previous chapter and have just set the system up for the first time before installing it.

When installed in the vehicle, the system is switched on when you switch the ignition on.

When the power is first switched on, the digital display will immediately show a "Low Oil P" warning and the alarm light will come on. The tachometer will reset itself by moving the needle until it touches the stop-pin and then moving it back to the zero RPM position. Press Switch 3 to clear the warning message from the display. (Switch 2 can also be used for this.)

The digital display panel and the analog dial face are always backlit when the system is switched on.

If none of these actions occurs when you switch on, switch off the power to the system and consult the section on troubleshooting in this manual.

### Changing the Display Layers

The digital display has five display layers. Each display layer shows three parameters and their values.

Each of the display layers is displayed in turn by pressing switch 3. Press switch 3 when display layer 5 is being displayed in order to return to display layer 1.

No.	Symptom	Possible Cause	Remedy	Notes
19	Display values and messages unclear or unreadable (poor contrast)	Display too hot or too cold	Ensure that the display is operated within the specified temperature range	Operating temperature is +5° F to +158° F
20	No RPM speed reading	Incorrect wiring	Check the connection of the engine speed wire to the ignition system (or sensor, if used)	See instructions supplied in this manual. If connected directly to the coil, check that it is to the switched low tension side (usually the negative side).
21	Displayed RPM value too high or too low by a constant %-age amount.	System configured with wrong number of engine cylinders.	Reconfigure system to correct number of cylinders.	Ignition systems may either: -produce "waste" sparks giving double the number of cylinders per revolution
		Ignition system pulses per revolution not same as number of cylinders	Reconfigure system to correct number of pulses per revolution.	-use multiple coils where each additional coil gives proportionately fewer pulses per revolution.

No.	Symptom	Possible Cause	Remedy	Notes
16	Switch 4 does not reset the trip value back to zero	Lap Marker Receiver triggered	Turn off Beacon	
		Switch 4 faulty	Replace switch	Disconnect the switch and short the leads together. If the display changes replace Switch 4. Otherwise check wiring.
		Faulty switch wiring	Check switch wiring for correct continuity.	Pin U to yellow S4 wire less than 1.0 Ohm and Pin U to Pin H (ground) greater than 1M Ohms)
17	External warning light dead when the display warning light is OK	Bulb has burnt out	Replace bulb	Swap with the other light to confirm burnt-out bulb. If not burnt out, check wiring.
		Faulty wiring to light	Check continuity of wiring.	Pin G to red AL wire less than 1.0 Ohm and Pin N to yellow AL wire less than 1.0 Ohm
		Driver circuitry burnt out	Return unit	
18	External gear shift light dead	Bulb has burnt out	Replace bulb	Swap with the other light to confirm burnt-out bulb. If not, check wiring
		Faulty wiring to light	Check continuity of wiring:	Pin G to red SL wire less than 1.0 Ohm and Pin M to green SL wire less than 1.0 Ohm

### Display Layer 1

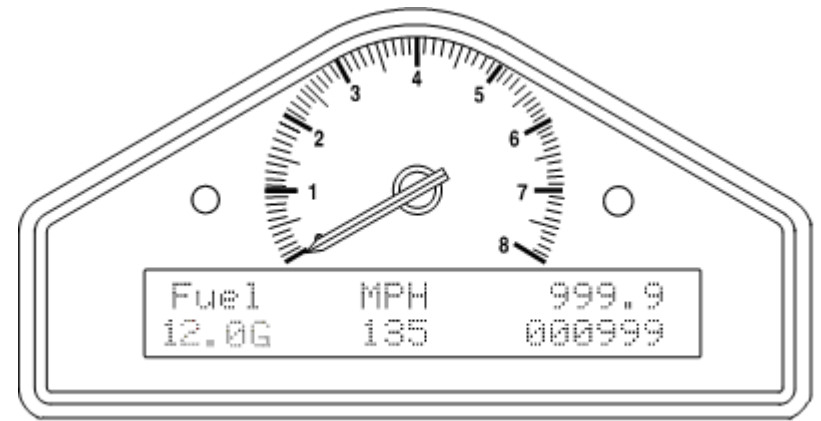

Display layer 1 shows:

- Fuel level (*Note that when the amount of fuel in the tank is changed the displayed value changes slowly (about 1/4 gallon every 5 seconds) to minimize the effects of fuel surge.*)
- Current speed (MPH)
- Trip indicator
- Odometer

Press Switch 3 to change the display to layer 2.

### Display Layer 2

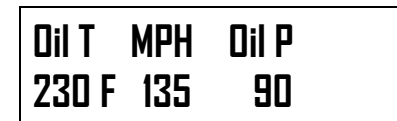

Display layer 2 shows:

- Oil temperature (Oil T)
- Current speed (MPH)
- Oil pressure (Oil P)

Note that the minimum oil and water temperature for which the display gives a true reading is 53°F. The unit displays temperatures that are less than this as 32°F.

**Display Layer 3**

<b>Water</b>	<b>MPH</b>	<b>Oil P</b>
<b>167 F</b>	<b>135</b>	<b>90</b>

Display layer 3 shows:

- Water temperature
- Current speed (MPH)
- Oil pressure (Oil P)

**Display Layer 4**

<b>Fuel P</b>	<b>MPH</b>	<b>Batt</b>
<b>65</b>	<b>135</b>	<b>12.6V</b>

- Fuel Pressure (Fuel P) (optional)
- Current speed (MPH)
- Battery Voltage (Batt)

**Display Layer 5**

<b>Lap 12</b>	<b>MPH</b>	<b>Best</b>
<b>1:35.10</b>	<b>135</b>	<b>1:35.06</b>

Display layer 5 shows:

- Number of the current lap
- Current speed (MPH)
- Last lap time
- Previous best lap time

Lap time can be recorded manually using Switch 4 or with the optional lap timing kit.

No.	Symptom	Possible Cause	Remedy	Notes
13	Switch 1: Show peak values does not work	Switch 1 faulty	Replace switch	Disconnect switch and short its leads. If display changes, replace Switch 1. Otherwise check wiring.
		Faulty switch wiring	Check switch wiring for correct continuity	Pin K to red S1 wire less than 1.0 Ohm and Pin K to Pin H (ground) greater than 1M Ohms)
14	Switch 2: Show last alarm function does not work	Switch 2 faulty	Replace switch	Disconnect switch and short its leads. If display changes, replace Switch 2. Otherwise check wiring.
		Faulty switch wiring	Check switch wiring for correct continuity.	Pin L to red S2 wire less than 1.0 Ohm and Pin L to Pin H (ground) greater than 1M Ohms)
15	Switch 3: Change display layer function does not work	Switch 3 faulty	Replace switch	Disconnect switch and short its leads. If display changes, replace Switch 3. Otherwise check wiring.
		Faulty switch wiring	Check switch wiring for correct continuity.	Pin U to orange S3 wire less than 1.0 Ohm and Pin U to Pin H (ground) greater than 1M Ohms)



No.	Symptom	Possible Cause	Remedy	Notes
8	Fixed pressure reading of -99 PSI	Pressure sensor has failed	Replace sensor	Disconnect sensor. If reading changes to that in 7 above, replace sensor
		Faulty sensor connections	Check continuity of sensor leads for short circuits	Check the wiring harness for short circuit
9	Fixed pressure reading of 0 PSI suspected low/slow reading	Pressure sensor has failed	Replace sensor	
		Faulty sensor connections	Check pressure connections	Check plumbing for a blockage (kinks in flexible hoses)
10	All sensors show fixed high values	Switch 1 (Peaks) faulty	Replace switch	Disconnect switch. If values return to normal, replace switch.
		Faulty switch wiring	Check switch wiring	Check wiring for short between connector pins K and H (ground)
11	Displays pressure values too low and temperature values too high	Low Battery voltage	Recharge battery	The system does not give accurate readings when voltage is below 9.0V
12	Peak values not updated	Gate value set too high	Change Gate RPM in the display configuration menu	Peak values only updated while the engine RPM is greater than the Gate value
		Internal memory battery dead	Return unit to Auto Meter for new battery service	Display shows !! Internal Battery Low !! warning on power up

## Peak Values (Tell Tales)

The system can display the peak values (sometimes called ‘tell-tales’) that have been recorded during a run for all the monitored parameters.

Peak values are updated only when the engine speed has exceeded its "gate value" for RPM *for at least one second*. This allows the values to stabilize. Blipping the engine may not be enough to update the peak values. The gate value is a predefined RPM value that is used to control when the system updates the peak values. This is to prevent abnormal peak values from being recorded when, for example, the engine is either not running, is idling or is being warmed up.

The system stores either a maximum or a minimum value as the peak value, depending on the parameter, as in the following table:

Parameter	Type of Peak Value	Gated to RPM
Engine Speed (RPM)	Maximum	No
Wheel Speed	Maximum	No
Oil Pressure	Minimum	Yes
Oil Temperature	Maximum	Yes
Water Temperature	Maximum	Yes
Fuel Level	Value at Reset	No
Battery Voltage	Minimum	No
Fuel Pressure	Minimum	Yes

## Displaying the Peak Values

Press and hold **Switch 1** to show the peak values for the parameters being displayed on the current layer. Release the switch to return to the normal display.

Note: The displayed peak fuel level is the value that was current when the peak values were last reset. The amount of fuel used since the peak value reset can be determined by subtracting the current value from the peak value.

## Resetting the Peak Values

You can reset all of the peak values manually. All peak values are reset at the same time. If the engine is running **at** or **above** its gate value when the peak values are reset, they are set to the current value of each performance parameter.

To reset the peak values:

- Press and hold Switch 1 to display the peak values.
- While holding Switch 1, press and hold Switch 4.
- With Switch 4 held down, you will see the display revert to the current values. The new peak values that are stored are those being displayed when you release Switch 4.

If the engine is running **below** its gate value, the peak values are not reset to the current values but are set to the values in the following table:

Parameter	New Peak Value
Engine RPM	Current value
Wheel speed	Current value
Oil Pressure	999 PSI
Oil Temperature	32F
Water Temperature	32F
Fuel Level	Current value
Battery Voltage	Current value
Fuel Pressure (optional)	High range sensor 999 PSI Low range sensor 99.9 PSI

No.	Symptom	Possible Cause	Remedy	Notes
5	Display gives a fixed temperature reading of 999° F	Temperature sensor has failed	Replace sensor	Disconnect sensor. If reading changes to 0, replace sensor.
		Faulty sensor connections	Check the continuity of sensor leads: with the sensor disconnected and the display powered up, there should be 6.25V between the sensor leads.	Otherwise check harness for short circuit
6	Water or Oil temperature display gives a fixed temperature reading of 0°F when the water temperature is either above 55°F	A temperature sensor has failed	Disconnect sensor and short its leads together. If the reading changes, replace the sensor	
		Faulty sensor connections	Check continuity of sensor leads for open circuits. See No. 5 above.	Check the wiring harness for open circuits (pin E to the red OT sensor wire, pin P to the red WT wire and pin H to both the black OT and WT sensor wires)
7	Fixed pressure reading of 999 PSI	Pressure sensor has failed	Replace sensor	
		Faulty sensor connections	Check continuity of sensor leads for open circuits. See 5 above.	Pin D to the red OP wire, pin R to the red F wire and pin H to both the black OP and F sensor wires

## Chapter 6. Troubleshooting

No.	Symptom	Possible Cause	Remedy	Notes
1	Display is dead  (no backlight, nothing on display, no green dial lights)	Ignition is off	Turn ignition on	<b>B +</b> is 19w connector pin G.  The power lead <b>B -</b> is 19w connector pin H.
		Battery is dead	Recharge or replace battery	
		Power connection to <b>B +</b> or <b>B -</b> is faulty	Check if battery is connected correctly. Check power lead continuity	
2	Display is dead (no backlight, nothing on display, green dial lights on but dim)  or Low Battery warning on display	Battery is almost dead	Recharge or replace battery	
		Power connection to <b>B +</b> or <b>B -</b> is faulty	Check power lead continuity	
3	Display flashes and  dial pointer resets or vibrates	Battery is almost dead	Recharge or replace battery	
		Power connection to <b>B +</b> or <b>B -</b> is faulty	Check power lead continuity	
4	The Low Oil P message does NOT appear on power up.  The warning light is not turned on.	Pressure sensor has failed	Replace sensor	A reading of 999 on the display indicates an open circuit connection (pin D to the red sensor lead and pin H to the black sensor lead)
		Sensor connections are faulty	Check for continuity on sensor lead.	
		Oil pressure alarm disabled	Check that the oil pressure alarm is set on	

## Peak Value Memory

The peak values are stored in a memory, which is powered by an internal back-up battery. They remain stored in this memory when the external power source is disconnected from the system. The internal battery needs to be changed every 4-5 years. When the power from this battery drops below a safe level, an alarm is triggered and the warning "Internal Battery Low" is displayed.

Note: Contact Auto Meter for service at (866) 248-6357 if this message is displayed.

## Alarms

The Display System has built-in warnings to alert the driver when certain parameters either exceed or fall below their alarm values. For example, a warning is signalled if the oil pressure falls below its alarm value or if the oil temperature rises above its alarm value. You can adjust the preset alarm levels when you configure the Display System. See Chapter 4, *Configuring the Display System* in this manual.

Some of the warnings (see the following table) are triggered only after the engine speed has exceeded its "gate value" for RPM **for at least one second**. Blipping the engine may not be enough to trigger a warning. The gate value is a predefined RPM value that is used to control when the system is to trigger a warning. This prevents abnormal warnings from being triggered when, for example, the engine is either not running, is idling or is being warmed up. Once the engine has been running above the gated RPM for at least one second, any problems will trigger an **immediate** warning.

Note: The oil pressure alarm will come on at power-up until the engine is started and pressure exceeds the threshold set for the alarm.

The Display System has the following built-in alarms:

Parameter	Alarm is triggered when the:	Gated to RPM
Oil Pressure	Current value drops below the preset value	No
Oil Temperature	Current value exceeds the preset value	Yes
Water Temperature	Current value exceeds the preset value	Yes
Fuel Level (warning light only)	Current value drops below the preset value	No
Battery Voltage	Current value drops below the preset value	No
Fuel Pressure (optional)	Current value drops below the preset value	Yes

### Displaying an Alarm

When an alarm condition occurs, the built-in red warning light turns on and the digital display gives a warning message to show the type of alarm:

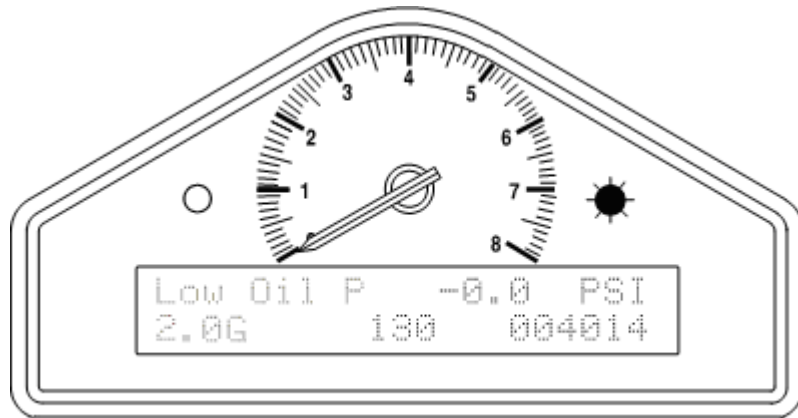

Note that the low fuel warning is indicated by the amber light.

### Clearing an Alarm

Press Switch 2 or Switch 3.

### Fitting the wiring harness

When fitting the harness on the vehicle, you should observe the following:

- Start by attaching the harness to the Display Module by connecting the 19-way military connector.
- Position the ends of all the wires at the locations of the sensors, lamps and switches to which each is to be connected, but do not connect them yet.
- All wires should be routed as far as possible and not closer than 2" from ignition coil and spark plug wire and distributor caps and any other sources of high voltages.
- When you pass any wire through a bulkhead or dashboard, fit a cable grommet or gland into the hole so that the edge of the hole cannot chafe the wire.
- Particular care is needed when passing wires through holes in carbon fiber, as the carbon can cut through cables very easily.
- The heatshrink sleeving around the sensor cables can be cut back, if necessary, to enable the sensor cables to go in separate directions earlier. It is recommended that you always leave at least 6" of heatshrink sleeving to provide additional strain relief for the cable where it enters the 19-way connector.
- Connect the wires when all the sensors are in position and you have secured the wiring harness.

### Wiring labels

See Chapter 2 if you need to check the labels used to identify the individual cables in the wiring harness

### Checks and Alarms

You should check the system to ensure that all the sensors are detecting the correct values. You should also run the engine at its operational levels to check that the values displayed by the Display System are accurate. You should then check out the alarm systems to ensure that they are functioning correctly before going out for a test drive.

### Power supply to Trackside beacon

The beacon operates from a 12v DC supply. A sealed lead-acid battery with a minimum rating of 2.5 Amp/hour is recommended. This provides about 15 hours of operation.

The condition of the battery is indicated by the color of the LED indicator on the front panel of the unit:

1. Green: The voltage is, at present, adequate for use
2. Red: The voltage is too low (replace the battery).
3. No Color: Battery exhausted or disconnected.

### Wiring harness

The Display Module, the sensors, switches and external lights for your Display System are connected together by means of the wiring harness supplied with the system.

The wiring harness can be fitted after the Display Module and all the sensors and switches have been installed.

This harness has been designed so that the various branches are long enough for most applications. Occasionally, an individual branch may need to be extended significantly. Contact Auto Meter or your Auto Meter dealer to purchase extension cables. Do not shorten the supplied wire harness. It is recommended that additional length is coiled and secured away from moving parts and high heat sources.

Extender wires for connecting the air temperature and wheel speed sensors to the wiring harness are available in lengths of either 2', 4' or 6'.

Model No.	Length
9524	2'
9525	4'
9526	6'

### Showing the Last Alarm

Press and hold Switch 2.

**Low Oil P -0.0 psi**  
**15 G 130 004014**

### Lap Times

The lap time for each lap is recorded either by the infra-red lap time sensor when passing the lap time beacon or when the driver presses Switch 4.

The most recent lap time is held in display layer 5. Press Switch 3 to see this display layer. This display gives you time of the last recorded lap and the lap number of the current lap.

**Lap 12 MPH Best**  
**1:35.10 135 1:35.06**

### Resetting the Lap Time to Zero

Press and hold Switch 1 and then press Switch 4 to reset the lap count and lap time to zero. The lap timer starts recording the time immediately.

**Lap 0 MPH Best**  
**0:00.00 0 0:00.00**

### Gear Shift Light

The optional external gear shift light comes on when the engine RPM exceeds a predefined value. See "Configuring the Display System" for information about setting this value.

## Chapter 4. Configuring the Display System

### Configuration Mode

You put the Display System into configuration mode by pressing Switches 1 and 2 together. This should give a display similar to the following:

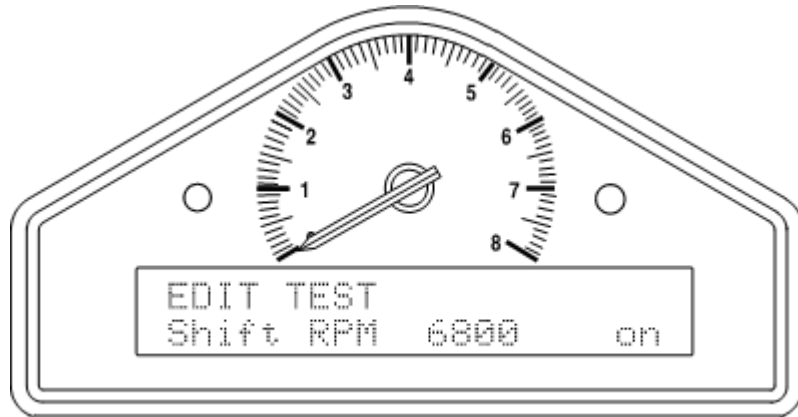

You then work through the configurable parameters in a preset sequence.

Press Switch 3 to display the next configurable parameter.

Press Switch 4 to exit configuration mode.

### Setting or resetting configuration values

Use Switch 1 to decrease the value being configured and Switch 2 to increase it. The rate at which the value increases or decreases itself increases while the switch is being held down.

## Trackside Infra-Red Lap Beacon (Optional)

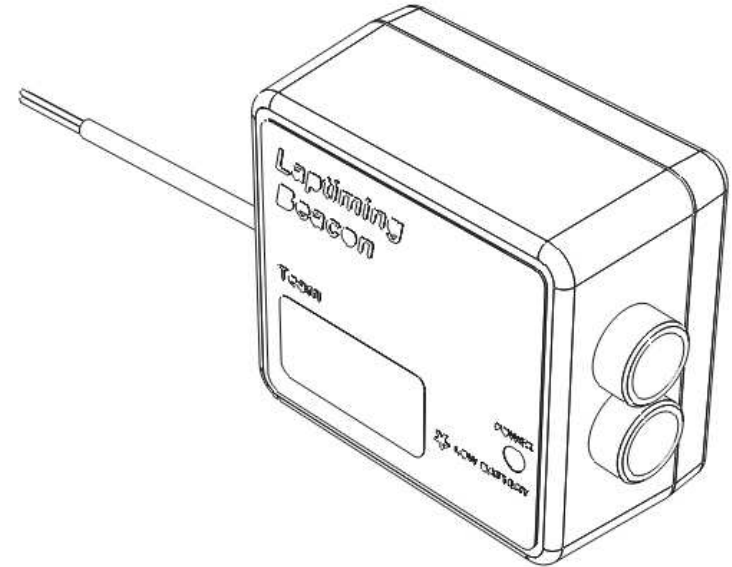

The trackside infra-red lap beacon should be located as follows:

- As near to the start-finish line as possible
- At the same height as the on-vehicle detector
- Level, so that it emits a horizontal beam
- It must be between 6 and 100 feet from the vehicle when the vehicle passes it

Avoid positioning it so that the sun is directly behind it when it is being used.

Where the unit is to be used for lengthy periods in very hot, sunny conditions, it should be protected by shading it from direct sunlight.

Do not allow water to be sprayed onto the transmitter lenses. During wet conditions, fit a protective shroud over the beacon.

## Lap Timing Sensor (Optional)

The lap timing sensor is actuated by an infra-red beacon positioned at the side of the circuit. The sensor is fixed to a rigid bracket mounted at a convenient position on the outside of the vehicle where it is able to detect the signals from the beacon.

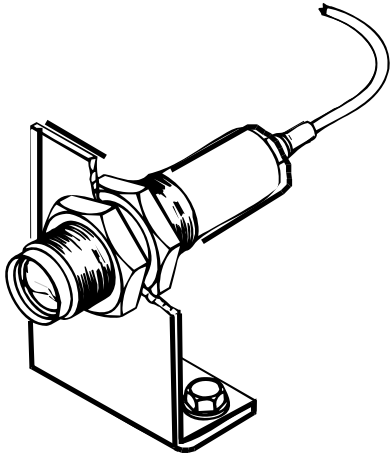

It is secured by two nuts (supplied) with an M18 x 1 mm thread.

This sensor must be positioned horizontally and square to the axis of the vehicle. In order to detect the signals from the beacon, it must be positioned outside the vehicle. It should, if possible, be positioned so that other vehicles that are being overtaken (or are overtaking) at the moment your vehicle passes the beacon do not block the signal.

Note that after detecting a signal, the system does not recognize any further signals from beacons for a period of ten seconds.

Note: Mounting bracket is not included.

## Switching Alarms on or off

You can enable (switch on) or disable (switch off) each of the alarm warnings by pressing and holding Switch 1 and then pressing Switch 2.

Note that you might change the preset value of the parameter slightly while pressing both switches. This does not matter if you are switching the alarm warning off and, if necessary, you can correct the preset value after you switch it on again.

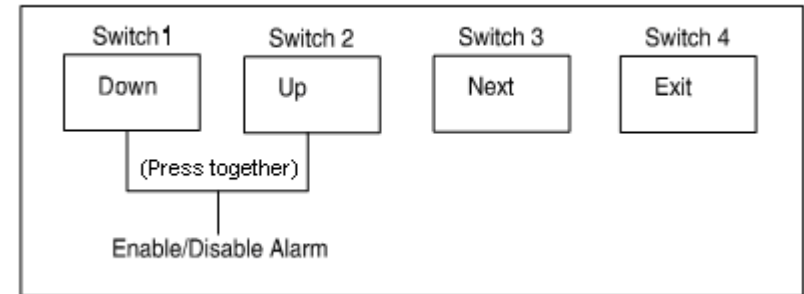

Summary of Configuration Switches

## Configurable Parameters

The configurable parameters are displayed in the following order:

Configurable Parameter	Setting Required	Switchable Parameter
Shift RPM	RPM at or above which the gear shift light is to come on	Yes
Low Fuel	Volume of fuel in tank at or below which the low fuel warning light is to be turned on.	Yes
High Oil T	Oil temperature at or above which the High Oil Temperature alarm is to be signalled.	Yes
High Water	Water temperature at or above which the High Water alarm is to be signaled.	Yes
Low Batt	Battery voltage at or below which the Low Batt alarm is to be signaled.	Yes
Low Fuel P (optional)	Fuel pressure at or below which the Low Fuel Pressure alarm is to be signaled.	Yes
Low Oil P	Oil pressure at or below which the Low Oil Pressure alarm is to be signaled.	Yes
Fuel Tank Sender	The volume of fuel currently in the tank. See "Calibrating the Fuel Level" on page 22 for more details.	Not applicable
Gate RPM	Minimum RPM for oil temperature, oil pressure and water temperature warnings to operate.	Yes
E. S. Cylinders	Number of cylinders in engine (for RPM)	Not applicable
W.S. Pulses/Rev	See "Wheel Pulses and Circumferences" on page 21 for more details.	Not applicable
Wheel Cir	See "Wheel Pulses and Circumferences" on page 21 for more details.	Not applicable

## VSS Pulse Amplifier Technical Specification

Supply :	From system input
Output characteristics :	compatible with system
Input impedance :	>50K Ohms
Operating temperature range :	-4 to 176 °F
Input threshold adjustment range :	-5 Volts to +12 Volts
Input hysteresis :	+/- 0.1 Volt
Maximum input frequency	2000 Hertz
Physical dimensions :	(mm) L 51, H 18, W 32 (in) L 2, H ¾, W 1¼
Weight :	50g / 2oz maximum
Vibration testing :	20 G, 50Hz to 2000Hz, 1 Octave/min for 12 hours

## Fuel Tank Sender

Plug the adapter supplied in the sensor bag to the 4-way sure seal connector marked **F**.

## Single-Wire Sender

If your vehicle is fitted with a single-wire sender (rheostat), remove the existing wire from it and connect the red (F) wire to it.

## Two-Wire Sender

If your vehicle is fitted with a two-wire sender (potentiometer), remove the existing wires and fit the red (F) wire to one of the terminals. If there is no change in fuel-level reading during calibration, fit the red wire to the other terminal.

In some cases, it may be necessary to attach a grounded wire to your fuel sender mounting flange for proper operation.



**Electrical**

The amplifier connects into the system via a four way Mini Sure Seal (MSS) socket, the larger of the two connectors on the amplifier. Use the extender cable supplied to connect the amplifier to the WS input on the harness.

Use the vehicle speed extension harness with a MSS connector at one end and two wires at the other to connect the amplifier to the speed sensor.

For a two wire sensor, connect sensor wires to the white and black wires on the cable.

For a three wire sensor, such as 5291 & 5292, connect black wire to common ground with sensor and connect the white wire to the sensor signal.

**Adjustment**

Once the system has been fully wired power should be applied.

At this stage it is desirable to arrange for the sensor to generate a low frequency signal by spinning the wheel slowly. The red LED at the end of the amplifier should be seen to flash as each signal is received. If the frequency is higher than approximately 10 flashes/second the LED may only appear to dim, as the flashing is too fast for the eye to see.

If this does not happen (the LED is always on or off) it will be necessary to adjust the input sensitivity of the amplifier to match the sensor. This is accomplished by turning the small screw head, which is recessed, in the hole adjacent to the LED. This should be adjusted until the LED flashes consistently.

The operation should be checked at the lowest possible frequency, as this is the most likely speed for problems to occur.

Following these adjustments, correct operation can be verified by observing the LCD speedometer at a range of speeds.

Example displays for each of the configuration items are shown below.

**Shift RPM:**

**EDIT TEST**  
**Shift RPM 7000 on**

**Low Fuel:**

**EDIT TEST**  
**Low Fuel 2 G on**

**High Oil Temperature:**

**EDIT TEST**  
**High Oil T 266F on**

**High Water Temperature:**

**EDIT TEST**  
**High Water 220F on**

**Low Battery Voltage:**

**EDIT TEST**  
**Low Batt 10.0 on**

**Low Fuel Pressure (optional):**

**EDIT TEST**  
**Low Fuel P 35 on**

**Low Oil Pressure:**

**EDIT TEST**  
**Low Oil P 35 on**

**Fuel Level Calibration:**

**Sw1 & 2 to calibrate**  
**Fuel Tank Sender**

**Gate RPM:**

**EDIT TEST**  
**Gate RPM 3000 on**

**Engine speed cylinders:**

**E.S. Cylinders 4**

**Wheel speed pulses:**

**W.S. Pulses/Rev 10**

**Wheel circumference:**

**Wheel Cir 25.3 in.**

**Using the 'dual-lock' fastener with Auto Meter sensors**

This is a high opening force 'Velcro-type' fastener system with identical mating halves. It is intended to be used for semi-permanent fixing applications and is not intended for frequent dismantling.

For best performance, the following precautions should be taken:

Bond strength is dependent upon the amount of adhesive to surface contact development. Firm application pressure develops better adhesive contact and thus improves bond strength.

To obtain maximum adhesion, the bonding surfaces must be clean, dry and well unified. Typical surface cleaning solvents are isopropyl alcohol/water mixture (rubbing alcohol) or heptane. Use proper safety precautions when handling solvents.

Ideal application temperature range is 70-100°F. Initial application to surfaces at temperatures below 50°F is not recommended because the adhesive becomes too firm to adhere readily.

To mount a sensor or housing on the vehicle

Take one of the supplied pieces of 'dual-lock' fastener, remove the adhesive backing and attach to the sensor or housing.

Take a second strip of the fastener and attach to the first piece by pushing them together firmly, ensuring correct alignment.

Remove the adhesive backing off the second strip of fastener and attach the sensor or housing to the vehicle in the desired position. Push against the fastener firmly to ensure maximum adhesion.

Do not try to separate the 2 strips of fastener immediately

The acrylic adhesive backing should be given 24 hours to achieve full bond strength.

If you require further fastener strip or have any comments, questions or recommendations regarding its use, please contact Auto Meter or your nearest distributor.

## VSS Pulse Amplifier Interface

### Introduction

This amplifier is designed to convert the output of an existing sensor, which generates a pulsed signal which is not compatible with the system's channel input requirements. This incompatibility may be caused by insufficient voltage or lack of output current drive capability.

The amplifier has negligible loading effect on the signal and includes the facility to adjust its sensitivity, so can be used with a wide variety of sensors.

**WARNING! For reasons of safety, NEVER connect the amplifier to an ABS speed sensor.**

### Installation

#### Mounting

The amplifier should be mounted, using the self-adhesive dual locking material supplied, in a position away from strong sources of heat and H.T. leads. It should be noted that this adhesive will not reach full strength for up to 24 hours.

On one side of the module there is a small red LED and a potentiometer access hole. This potentiometer is used to alter the sensitivity and the LED is used to give visual confirmation of correct adjustment. Access to this part should therefore be considered when choosing a mounting position.

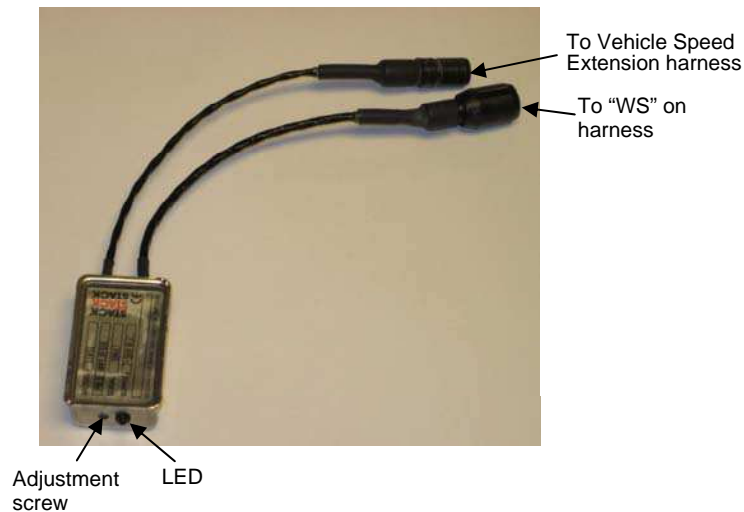

## Wheel Pulses and Circumferences

### Calculations for the VSS Pulse Amplifier

You must supply a value for the wheel circumference that you obtain from one of the following calculations:

If you know the number of pulses generated for one mile (US version only):

$63360 \div \text{pulses per mile} = \text{wheel circumference}$   
(Set the number of pulses per rev to 1.)

Note: If the resulting circumference is less than 20.0 inches, double this value and set the number of pulses per rev to 2. This is to make the calculated speed and distance as accurate as possible.

Example:

Pulses per mile: 5000

Circumference =  $63360 \div 5000 = 12.67$  inches

Double the two values:

Wheel Cir (ins) = 25.3 inches

W.S. Pulses/Rev = 2

### Configuring the Fuel Pressure Sensor (optional)

This sensor is highly accurate and it is no longer physically required to change sensors for high or low fuel pressure.

## Calibrating the Fuel Level

To calibrate the fuel level reading with the actual amount of fuel in the tank, you will need to start with a tank that contains the amount of fuel you require for its reserve and progressively fill it with known quantities of fuel. While filling the tank, you must use at least two and possibly as many as ten (the maximum permitted) calibration points to set values for accurate fuel level readings. More than five calibration points are recommended, with the first at zero (empty), the second at one gallon, the third at two gallons and the remaining points divided equally across the amount of fuel still required to fill the tank completely.

Use the following procedure:

Set the Display System to configuration mode.

1. Decide how many calibration points and the amount of fuel for each that you are going to use. For example, to calibrate the readings for a 10 gallon tank for the following quantities, the following seven calibration points are suggested: 0, 1gal, 2gal, 4gal, 6gal, 8gal, 10gal.

For a 20gal tank, ten calibration points are suggested: 0, 1gal, 2gal, 4gal, 6gal, 8gal, 11gal, 14gal, 17gal, 20gal.

Empty the tank so that it contains only the amount you require as its reserve. Use the fuel pump to empty the tank. Add the reserve fuel, for example, 0.5 gal.

You may wish to enter these values into the table on page 25. If you ever have to return the unit for servicing, supplying the values from this table will allow Auto Meter to automatically recalibrate the fuel display so that you will not have to repeat this process.

You should now drive to your local gas station. Fill the car on level ground in order to complete the calibration process.

To make the calibration process more efficient it is recommended that you have one person to operate the gas pump & one person to operate the switches for the Dash.

## Pressure Sensors

### Fitting the pressure sensors

The system is supplied with one pressure sensor for Oil Pressure. This sensor has a 1/8" NPTF thread.



### Installing the pressure sensors

- Position each sensor and its cable as far as possible from all sources of intense heat and from the ignition HT leads.
- The sensors can be either screwed in directly to the monitoring point or fitted separately by using suitable pressure hose to connect them to the monitoring point. By fitting the sensors separately, you will reduce the amount of vibration to which they are subjected and thereby extend their life.
- Do not over-tighten the sensors.
- The Fuel Pressure sensor must be connected to the A connector on the harness. A 55" extender cable is supplied if the standard harness is too short.

## Temperature Sensors

The Display System is supplied with two temperature sensors:

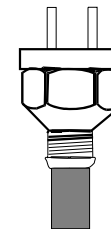

The temperature sensor has two terminals and a 1/8" NPTF thread

Each sensor can be used for monitoring both oil temperature and water temperature.

### Fitting the temperature sensors

Mount each temperature sensor directly in the appropriate fluid line. Screw the sensor into a suitable mounting boss, so that its end lies in the middle of the flow of fluid (when applicable).

- Position the sensors and their cables as far as possible from sources of intense heat and from the ignition HT leads.

## Series Resistor Connection

For systems which require series resistor on the ES (Engine Speed Wire) the resistor must be connected directly to the terminal to limit interference from the spark plug and coil wires (which must be the shielded type).

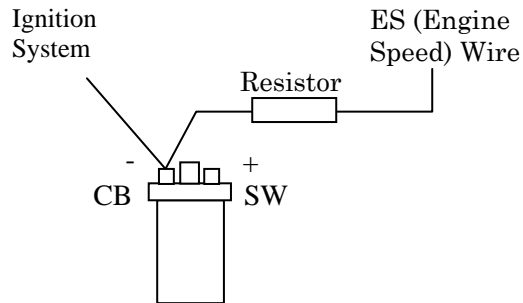

## Electronic Ignition or ECU Connection

Connect the ES (Engine Speed) wire directly to the “Tacho” output of the electronic ignition or ECU. If this results in a Zero RPM reading with the engine running then ...

Some ECU's (GM LS-1) require a Pull-up resistor connected between the ES wire & +5v (reference wire). Resistor value of 10,000 Ohms is required.

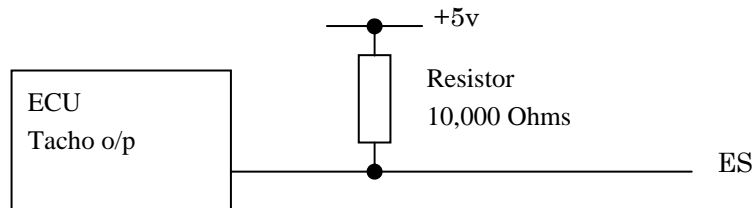

Note: The gas pumps may shut off, if the gas delivery is interrupted for a time.

2. Select the Fuel Tank Sender calibration display.

Hold Switch 1 down and press Switch 2. This gives a display similar to the following:

**Tank Qty 0G**  
**Reading 255\***

\*Ohm Reading from sensor at Tank Qty value

- (1) Use Switches 1 and 2 to change the Tank Qty value to zero if it is not already zero. Switch 1 decreases the value shown while Switch 2 increases it. Record the Tank Qty and the Reading value in the table on page 25.

When you have set the Tank Qty to the required value, press Switch 3 to set this value.

- (2) Press Switch 1 to continue to the next calibration point.
- (3) Fill the tank with a small, known amount of fuel, for example, one gallon. If the Reading value does not change, there is a problem with either the fuel sender or the wiring.
- (4) Wait for the Reading value to stabilize. This requires several seconds. While you are waiting for the Reading value to stabilize, use Switch 1 and Switch 2 to change the Tank Qty value to the amount of fuel now in the tank.
- (5) When the Reading value has stabilized, press Switch 3 to set this value
- (6) Repeat steps 6 through 9 above for each calibration until the tank is full or you have performed at least two or as many as ten calibration operations.
- (7) Press Switch 2 (Finished) when you have completed calibrating the fuel level readings.

You can press Switch 4 to go to the cancel calibration mode, then Switch 1 to Cancel or Switch 2 to Continue with calibration. Cancelling the calibration leaves the original calibration set. The flowchart below summarizes the steps in the calibration process.

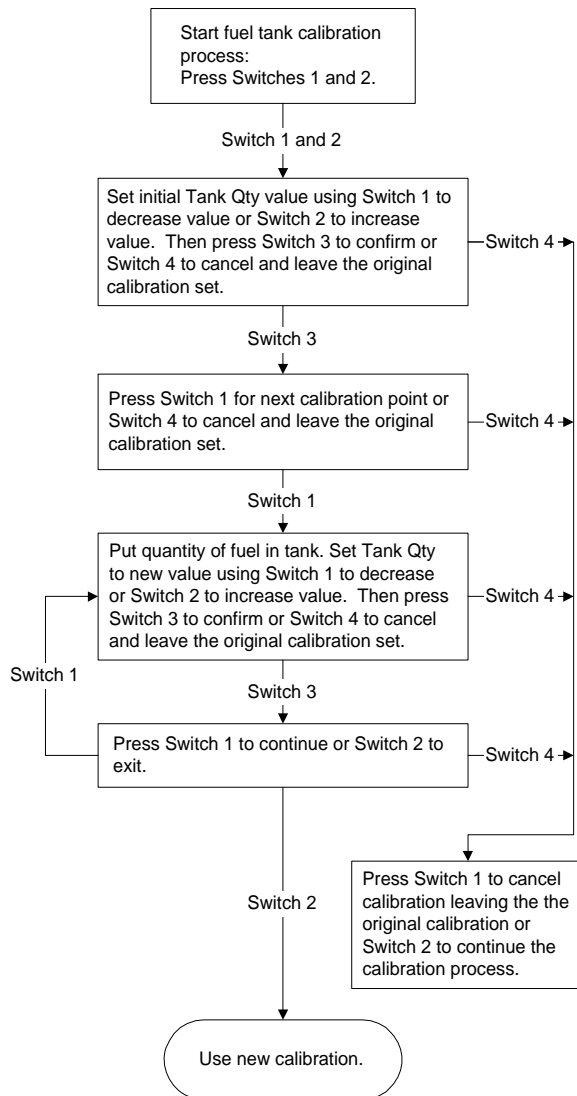

## Connecting the Display System to the Ignition System

The Display System can be connected to engines with a variety of ignition systems. Please see below.

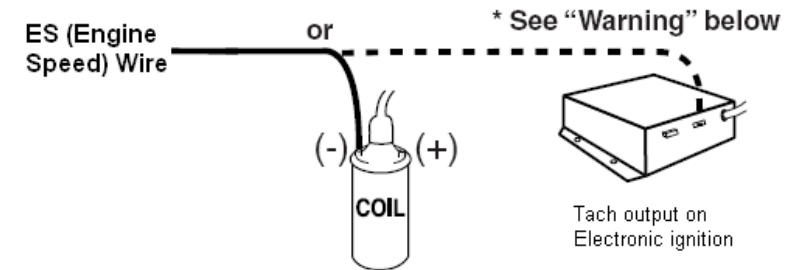

### \* WARNING

Warranty will be void if connected to coil when using an aftermarket ignition box such as, but not limited to products from the following manufacturers: MSD, Crane, Jacobs, Mallory, Holley, Etc.. Prior to installation, check with the ignition box manufacturer for recommended tachometer signal location.

See [autometer.com/tech\\_installation.aspx](http://autometer.com/tech_installation.aspx) for specific vehicle information.

The following connections are shown in greater detail:

- Series Resistor Connection
- ECU Connection (+ Pull-up resistor)

The connection of the Display System to these types of ignition system is described on the next page:

## Warning Lights

The Display Module has two built-in warning lights. The left-hand (amber) light is the fuel level warning light and the right-hand (red) light alerts the driver whenever an alarm has been triggered.

As an option, you can install additional external warning lights for gear shift and alarm warnings. The external warning lights should be installed in any position that is in the driver's direct line of vision, as they need to be visible at all times.

- ⇒ If you are using your own warning lights, ensure that the bulb rating does not exceed 2 Watts; otherwise the Display Module will be damaged. If you need to use lamps greater than 2W, connect them to relays and use the output sockets from the Display Module to switch these relays.

## Shift Light

Auto Meter offers a direct plug-in shift light (model no. 9580) for use with this system.

## Engine Speed (RPM) Measurement

The engine speed (RPM) is measured by connecting the engine speed wire directly to the ignition system. A single wire, with the label ES, connects the Display System to the ignition system or low-tension negative side of the coil (see warning on the next page).

If the displayed reading values do not change by a significantly large amount from the empty to full condition, the fuel level sender in your vehicle may not be suitable for use with the Street Dash Display System. Check with Auto Meter if this is the case.

When you wish to return to the normal display, press Switch 4.

Fuel Calibration Table

	Fuel Qty	Reading
1		
2		
3		
4		
5		
6		
7		
8		
9		
10		

## Chapter 5. Installing the Display System

### Who can install the Display System?

The Display System can be installed by anyone competent in fitting electrical and mechanical accessories to cars.

### Tools Needed to Install the Display System

A trimmer tool or small flat jeweller's screwdriver (1.5mm or 1/16 inch blade) is required in order to adjust the VSS pulse amplifier.

### Preconfigured Display Systems

Use the instructions in the previous chapters to set up, operate and configure the display before installing it in the vehicle.

### Fitting the Display Module

The Display Module is fitted into a cut-out in the instrument panel/dashboard and secured using the two U-brackets at the rear. The dimensions for the cut-out are shown below. A full size template is supplied at the end of this manual.

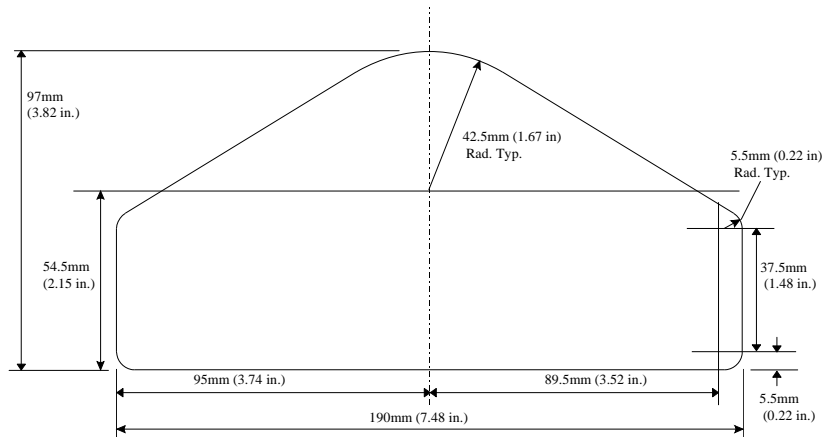

### Positioning the Display Module

Ensure that there is sufficient space behind the cut-out to allow the wiring harness to be connected to the 19-way connector without any tight bends to the wiring near the connector.

The Display Module must be positioned on the dashboard so that the driver can see it, either over the steering wheel or through it.

The Display Module should be aligned so that the driver looks at it square or from slightly above or below.

### Switches

The four switches are used to control the functions of the Display System.

The normal functions of the four switches are :

Switch	Functions
Switch 1	Show the peak values.
Switch 2	Clear an alarm or show the last alarm.
Switch 3	Change the display layer or clear an alarm.
Switch 4	Reset the trip distance to zero and start the lap timer. The trip distance is reset after each lap.
Switches 1 & 2	Enter Set up mode.
Switches 1 & 4	Reset the peak values and lap times.

You can install the switches in any convenient location. When installing the switches, you should take account of the following considerations:

- Drill a half inch hole in a suitable panel or manufacture a bracket with a hole in it.
- Insert the switch from the reverse side of the panel and screw on the rubber cover from the front. Do not over-tighten the nut; just greater than hand-tight should be enough.
- The cable for each switch is approximately 16" in length from the 19-way military connector.
- It is important that the driver is able to reach Switch 3 easily in order to change the display and clear warning messages after alarms. This switch can be fitted on the steering wheel.
- When you configure the system, you use Switches 1 to 4 for selecting the parameters and setting their values. These switches should be installed so that you can reach them easily when you are viewing the digital display.